

## CS系列

CS: 标准中间节联结方式, 双组膜片补偿

CS: Standard middle shaft connection ,compensated through two sets membranes

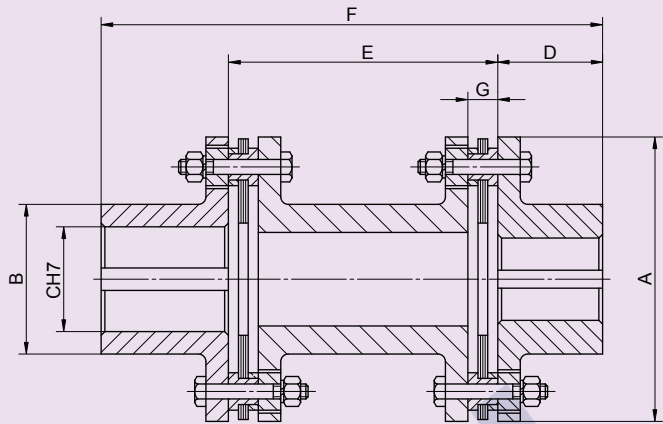
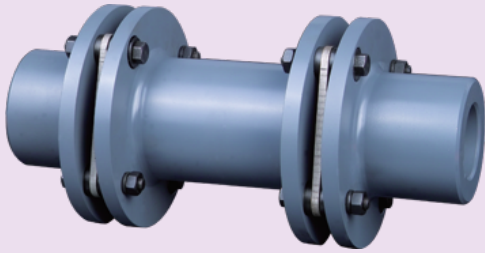

参数表

型号 Type	功率/转速 Power/Speed Pc/n ( $\frac{kW}{r/min}$ )	公称扭矩 Nominal torque (r/min)	最大许用转速 Max Permissible speed Nmax (r/min)	最大使用补偿值 Max Permissible compensating Value		A (mm)	B (mm)	Cmax (mm)	D* (mm)	E* (mm)	F* (mm)	G (mm)
				角向 Angular max(°)	轴向 Axial amax(mm)							
CSD4	0.004	40	4500	1	2.5	90	52	38	45	70	160	9.0
CSD10	0.010	100	4300	1	2.8	105	60	42	50	90	190	11.6
CSD16	0.016	160	4200	1	3.2	120	76	55	65	80	210	11.6
CSD32	0.032	315	4100	1	3.5	135	85	60	70	100	240	13.0
CSD82	0.082	800	3800	1	4.5	148	97	70	85	100	270	13.0
CSD100	0.104	1000	3600	1	5.5	170	105	75	90	130	310	15.3
CSD160	0.162	1600	3200	1	6.0	200	120	85	100	150	350	18.8
CSD260	0.260	2500	3000	1	7.0	215	125	90	110	150	370	18.8
CSS42	0.042	400	4000	2/3	2.6	138	85	60	70	100	240	11.6
CSS130	0.130	1250	3700	2/3	3.0	172	105	75	90	130	310	15.3
CSS210	0.210	2000	3200	2/3	3.1	202	125	90	110	130	350	18.8
CSS320	0.320	3150	3200	2/3	3.4	225	140	100	120	160	400	18.8
CSS410	0.410	4000	3000	2/3	3.5	246	160	110	130	150	410	18.8
CSS650	0.650	6300	3000	2/3	4.5	276	175	120	145	150	440	20.0
CSS810	0.810	8000	3000	2/3	4.8	297	195	140	165	180	510	20.0
CSL1600	1.620	16000	3000	1/2	2.0	297	195	140	165	190	520	20.0
CSL2000	2.060	20000	2500	1/2	2.3	316	210	150	180	220	580	22.0
CSL2500	2.570	25000	2500	1/2	2.4	336	220	155	185	230	600	24.0
CSL3200	3.240	31500	2500	1/2	2.6	356	235	160	190	250	630	27.0
CSL4100	4.120	40000	2200	1/2	2.8	376	250	170	225	270	680	27.0
CSL5200	5.220	50000	2000	1/2	3.0	396	260	180	240	270	720	31.0
CSL6700	6.770	63000	1800	1/2	3.2	426	285	200	240	290	770	31.0

“\*” 表示的数值为参考值, 最终数值由客户端确定 “\*” is reference value, final value should be decided by end user